

MEETING 1/2021

AIRPORT COMMUNITY CONSULTATIVE COMMITTEE
JANUARY 14, 2021

CONDUCTED ONLINE VIA MS TEAMS

Agenda

- Welcome & Introductory Remarks
- Review of Terms of Reference & Focus
- Review Previous Action Items
- Noise Profile and Operational Update
- NAV Canada Update
- Member Round-Table

Health & Safety Moment

Alberta Health Services Physical distancing works

811 Health Link Health Advice 24/7

Home | Contact | Staff | Help | Patient Feedback

Search AHS

COVID-19 info for Albertans & Health Professionals and about Family Support & Visitation.
COVID-19 testing / criteria and test results.

ABOUT AHS | FIND HEALTHCARE | INFORMATION FOR | CAREERS | NEWS | AHS IN MY ZONE

Home > Program & Service Information > Access Mental Health

Access Mental Health - Calgary Zone

Helping you find the information or service that's right for you.

Need Immediate Help?

If this is an emergency call [911](#)

- Call [Distress Centre Calgary](#)
- Go to the nearest [urgent care centre](#) or [emergency room](#)
- [Addiction & Mental Health Helplines](#)
- [Know Your Addiction and Mental Health Options](#)

Call Us

View [Access Mental Health](#) for details.

For non-urgent cases only. No referral needed.



Resources for Albertans

Helplines & Services

- [Addiction & Mental Health](#)
- [Together We're Better](#) (brochure)

Health Information - MyHealth.Alberta.ca

- [Mental Health Problems and Stigma](#)
- [Youth Addiction and Mental Health - Help4Me](#)

Resources for Providers

- [Addiction & Mental Health](#)
- [Ordering Mental Health Resources](#)
- [Promotional Materials](#)
- [Ways to Wellness Toolkit](#)

<https://www.albertahealthservices.ca/services/page11443.aspx>

Share | Report a problem | Go to top

GIVE | PAY | PATIENT FEEDBACK



Review Terms of Reference & Focus

- What, if anything, needs to be added, removed or changed in the **purpose**?
- Where do you see this committee going in 2021?
- Are there topics of interest you would like to learn more about?





NOISE PROFILE AND OPERATIONAL UPDATE

YYC Airport Operational Summary

Aviation significantly affected by COVID-19; Passenger volume equivalent to 1994/1995 levels

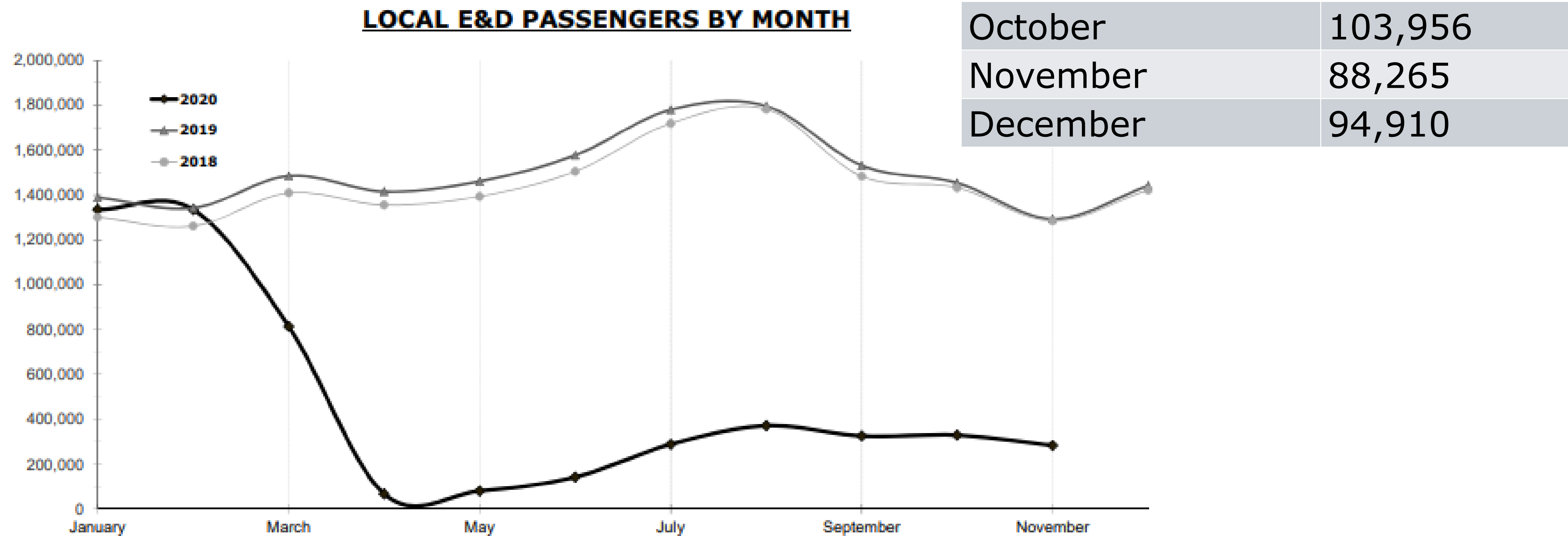

YYC Airport Operational Summary

Cargo volumes are increasing (by approx. 12% in 2020 over 2019)

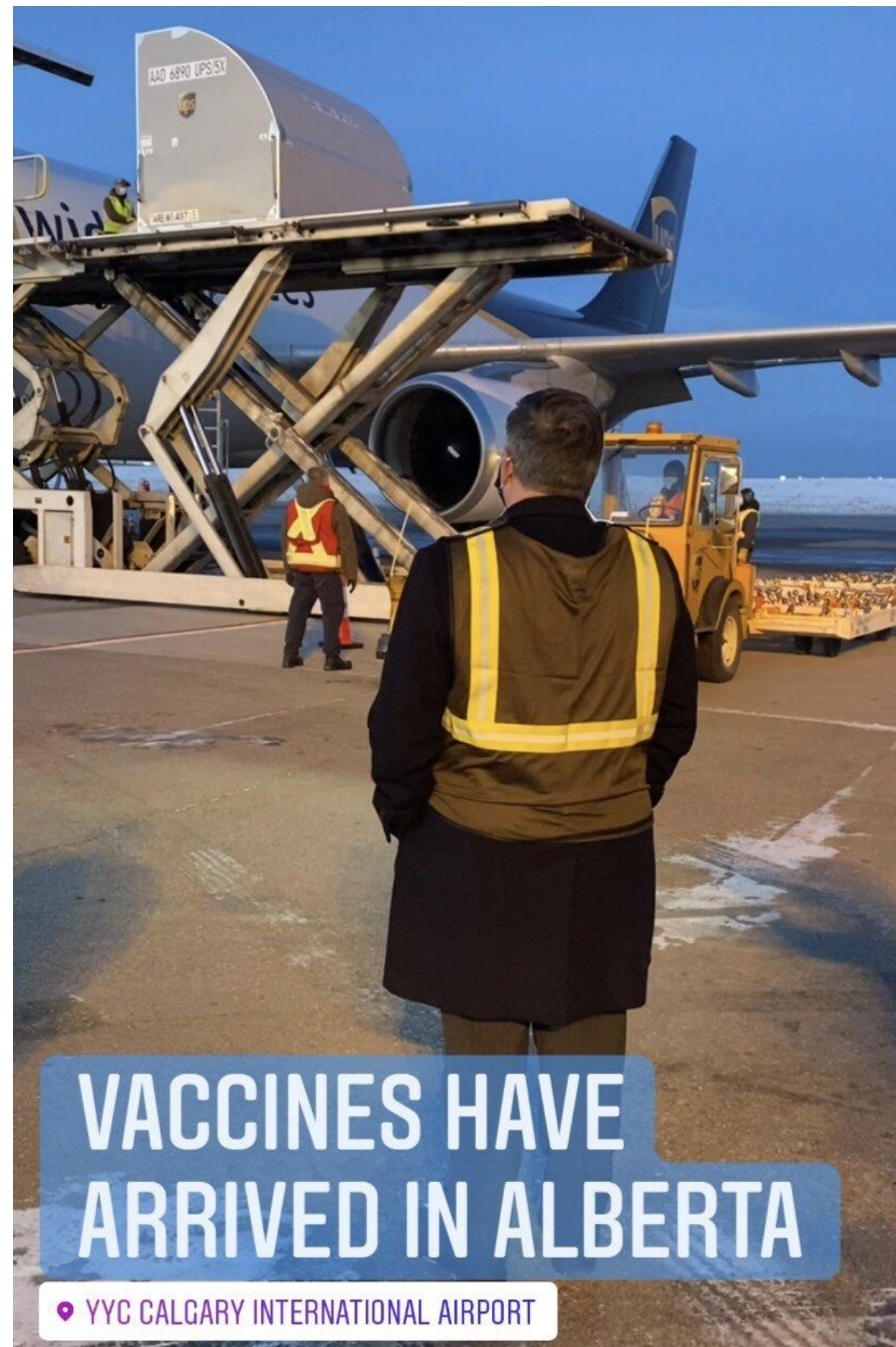

Year	Cargo Movements
2019	4,305
2020	4,821 (prelim data)

Calgary Zoo @calgaryzoo · Nov 27, 2020
Hanging at the International Animal Lounge Frankfurt - all is well!
[#GetThePandasHome](#) @Lufthansa_Cargo @FlyYYC



YYC Airport Operational Summary

Refining airport facility use and operations

- Centralized deicing
 - Improves deicing fluid usage
 - Reduces GHG emissions
 - Improves operational efficiency
 - Optimizes the glycol recycling and treatment facilities
- #FlyHealthyYYC
 - Ensuring we can make the experience as safe as possible for travelers to/from Calgary
 - Modifying check-in and passenger movement in the terminal
 - International screening pilot

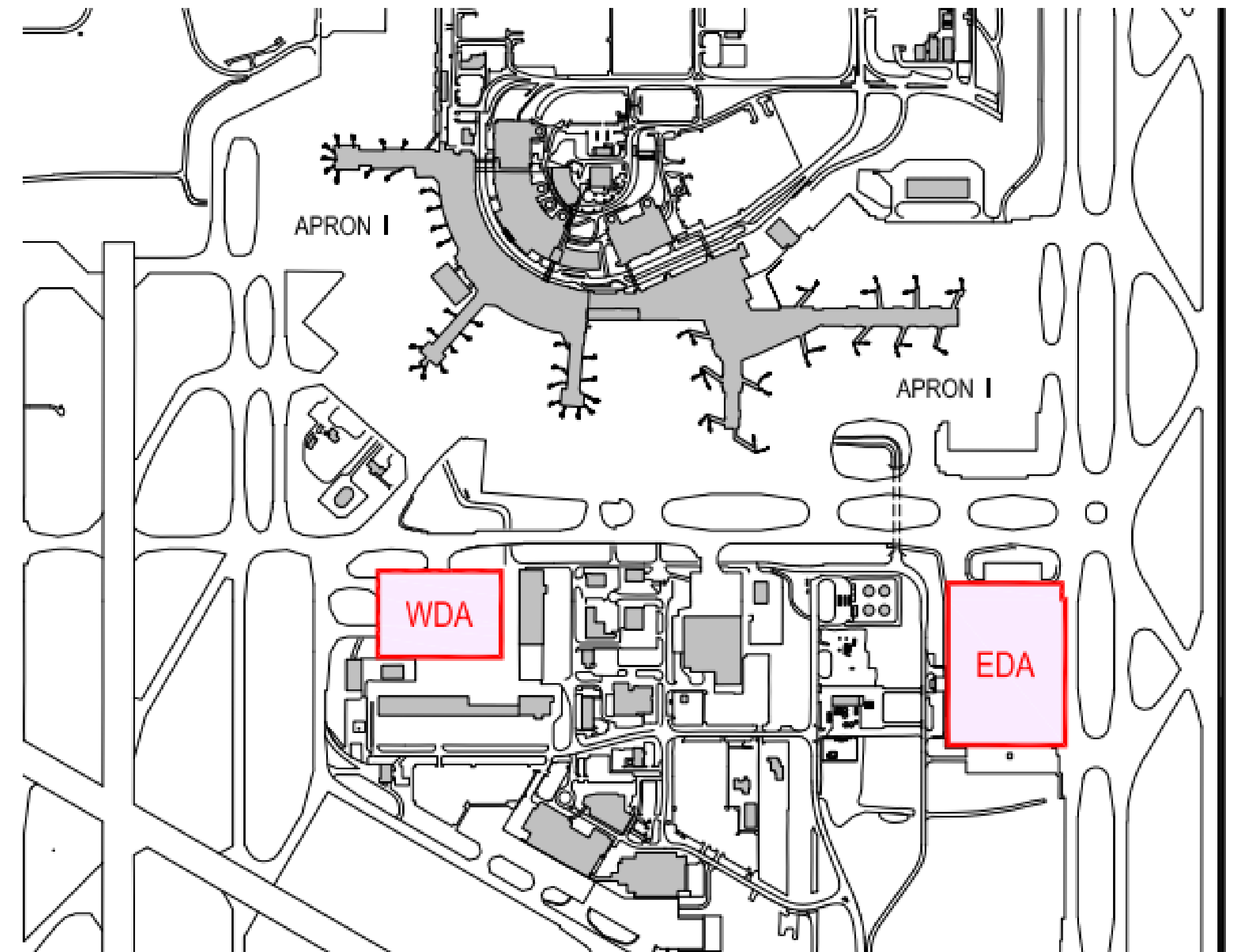

YYC Airport Operational Summary

Refining airport facility use and operations

- Helicopters and VFR Traffic
 - More attention of the community on these flights
 - No significant changes compared to previous year
 - YYC, NAV and Operators will begin planning for peak operations in summer



Dani Lantela/Global News

Runway Usage October to December 2020

Total Movements by Runway
January - December 2020

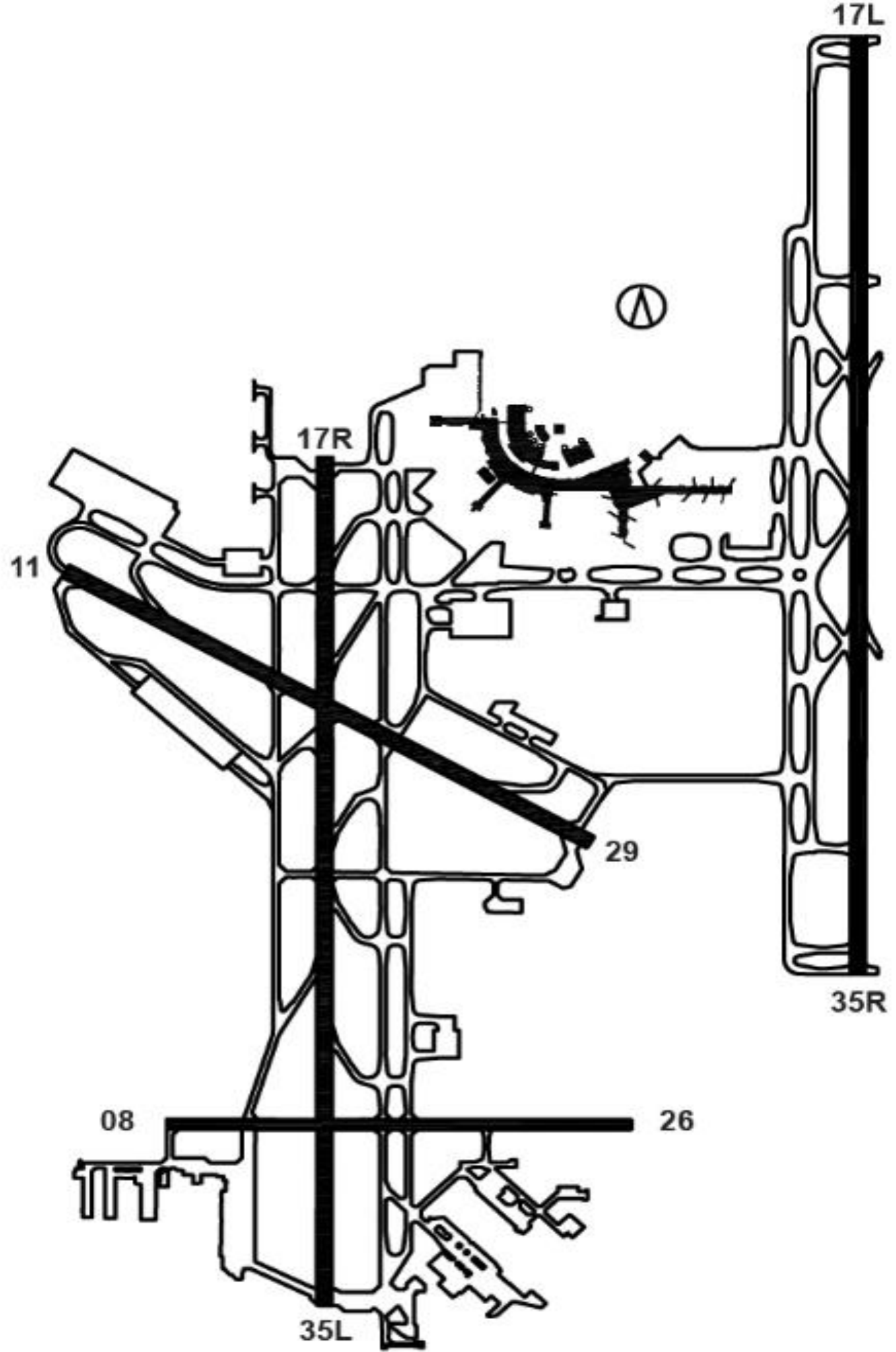
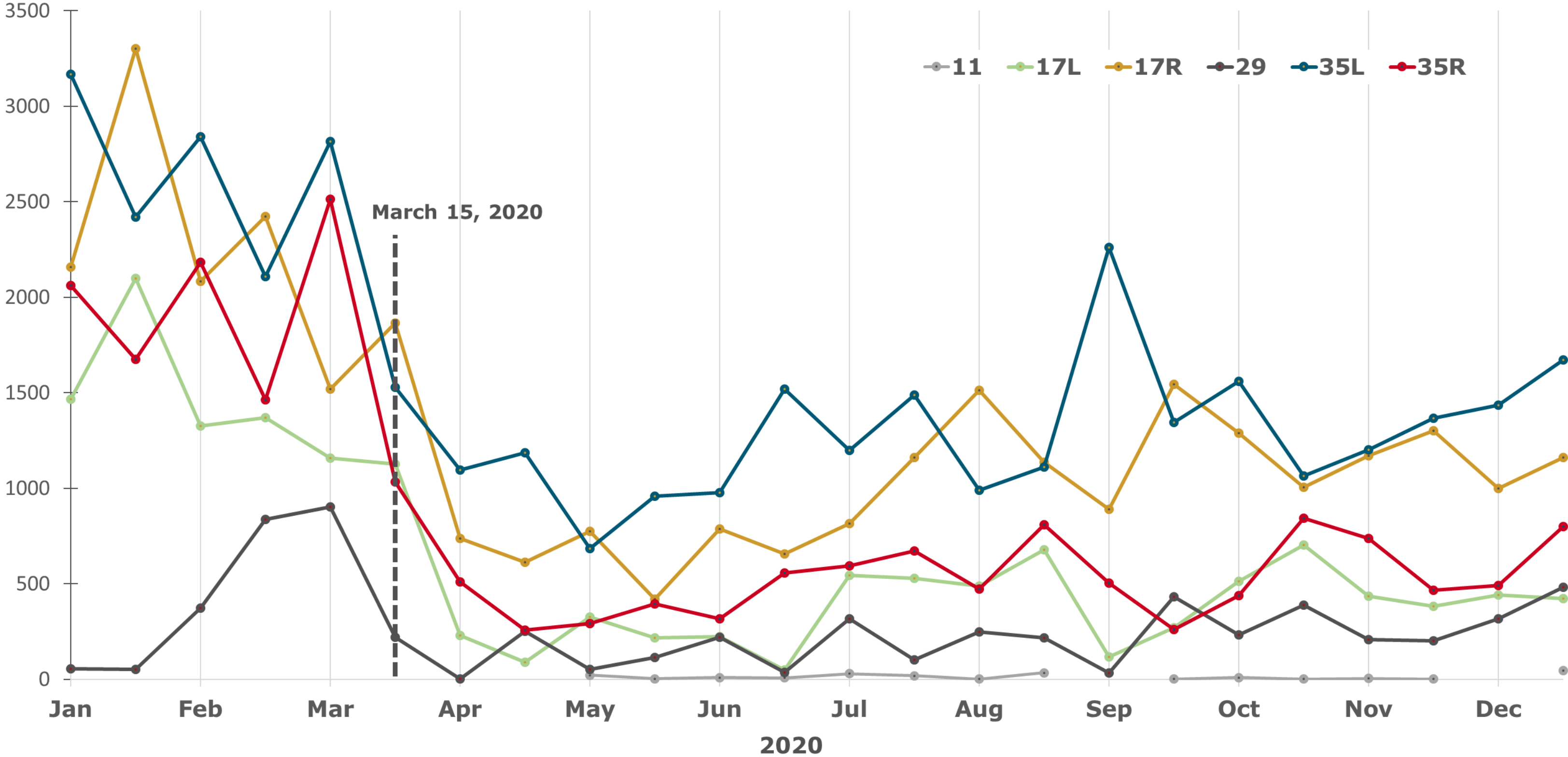

Average Movements/Hour

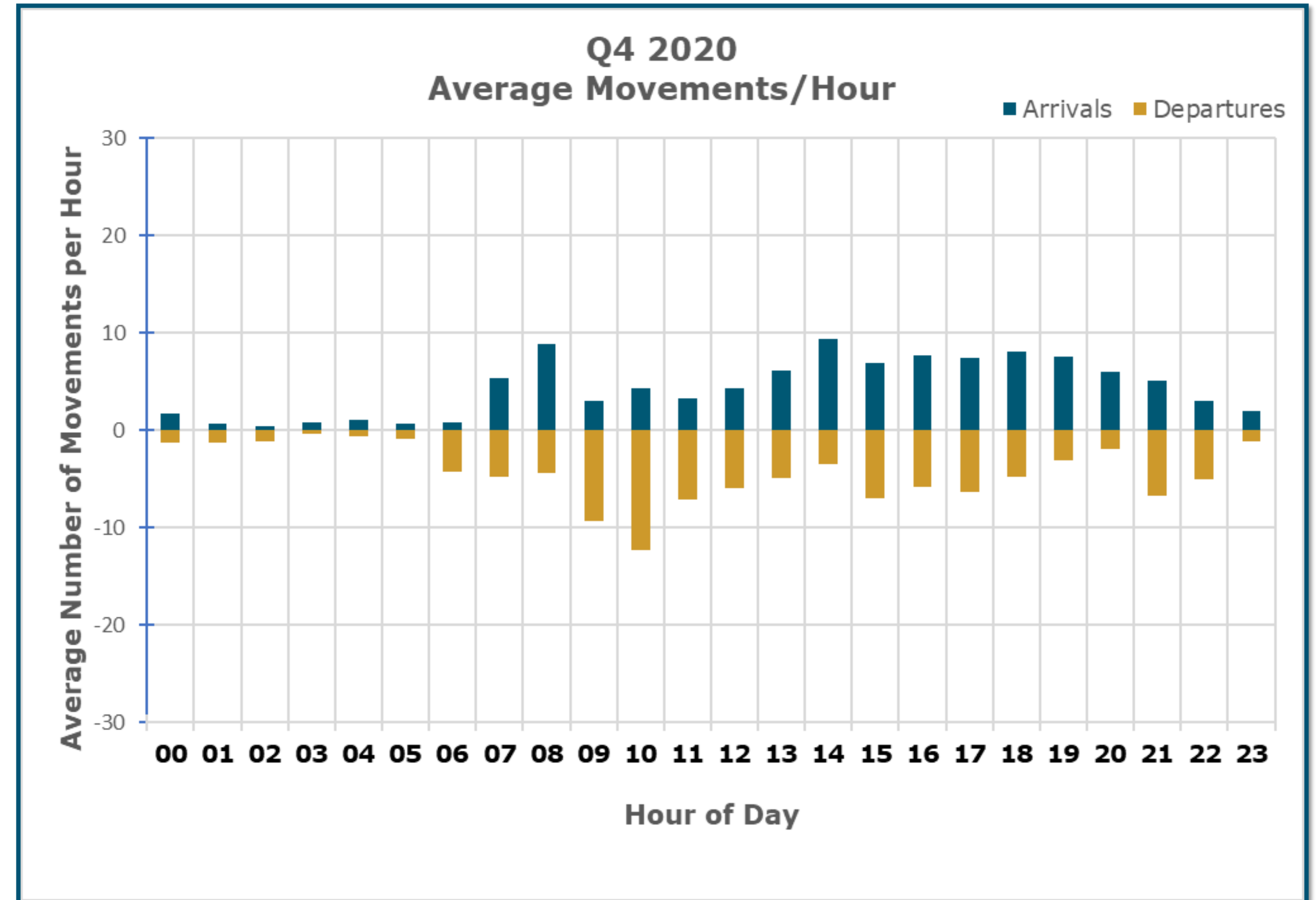
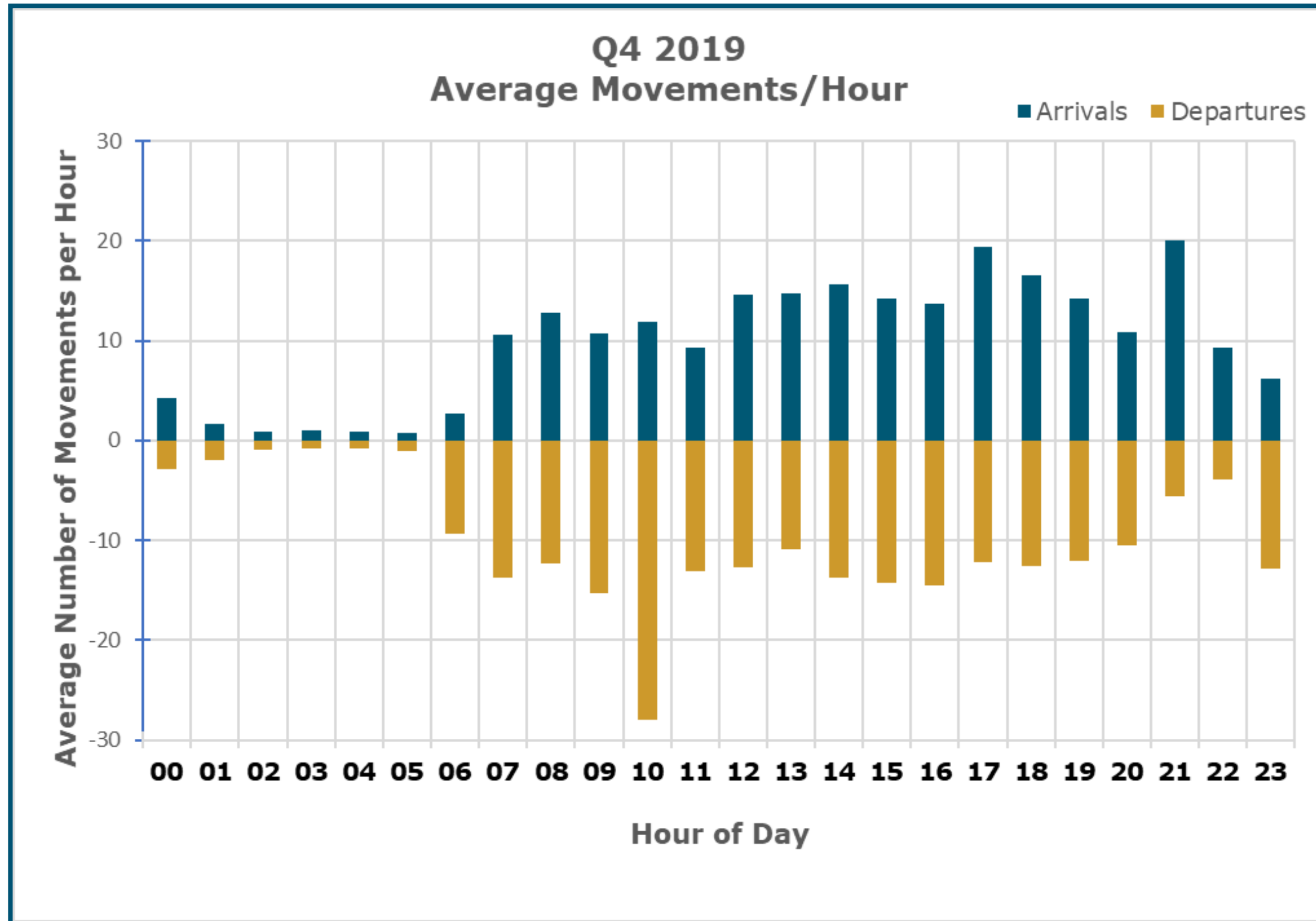

Household Noise Concerns by Community

Q2/Q3 2020

77% of concerns came from 3 households

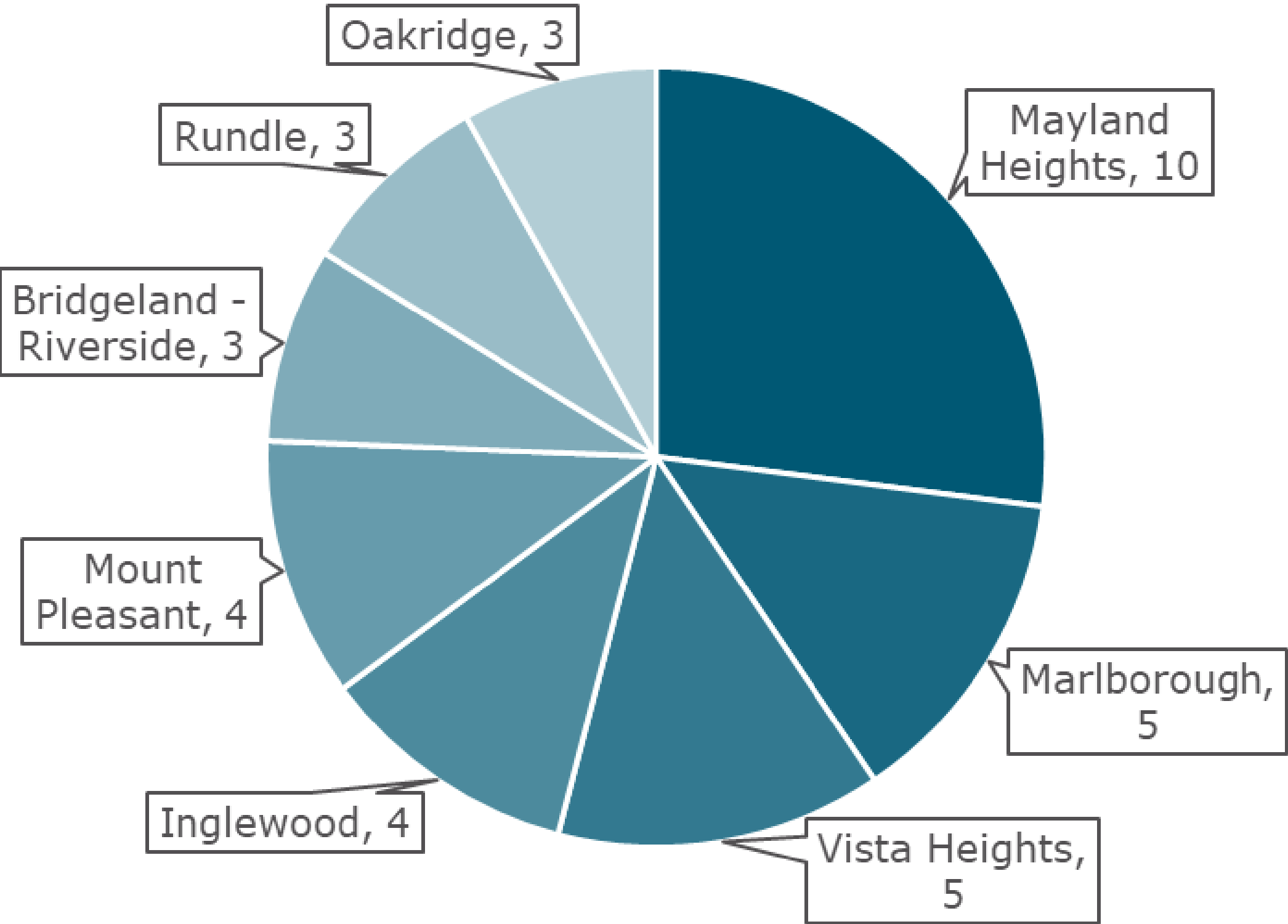

Q4 2020

75% of concerns came from 5 households

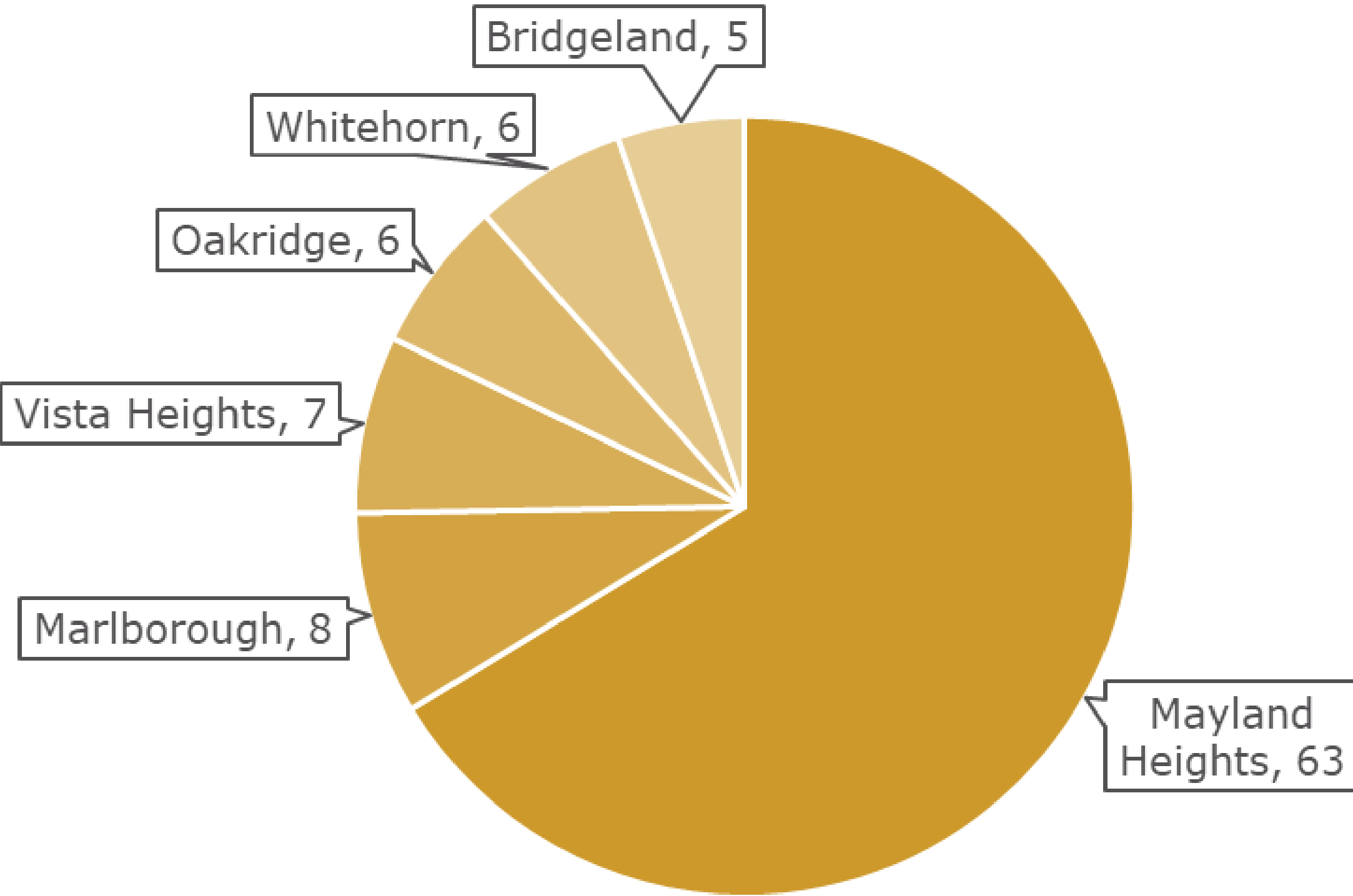

YYC Airport Operations – Helicopter and VFR Traffic

Q4 VFR Traffic 2019 & 2020
(Number of Movements)

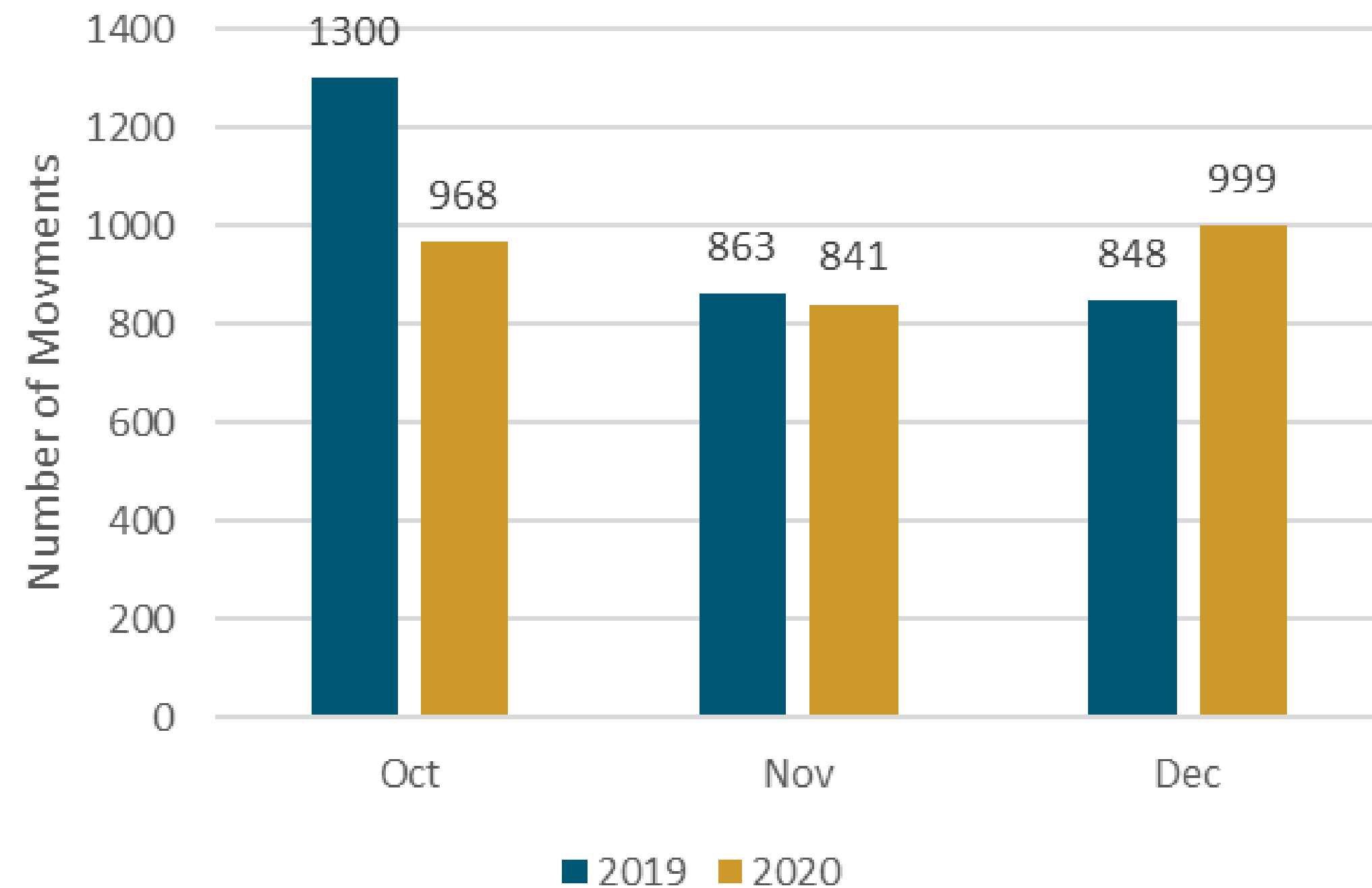

Q4 VFR Traffic 2019 & 2020
(Percent of Total Movements)

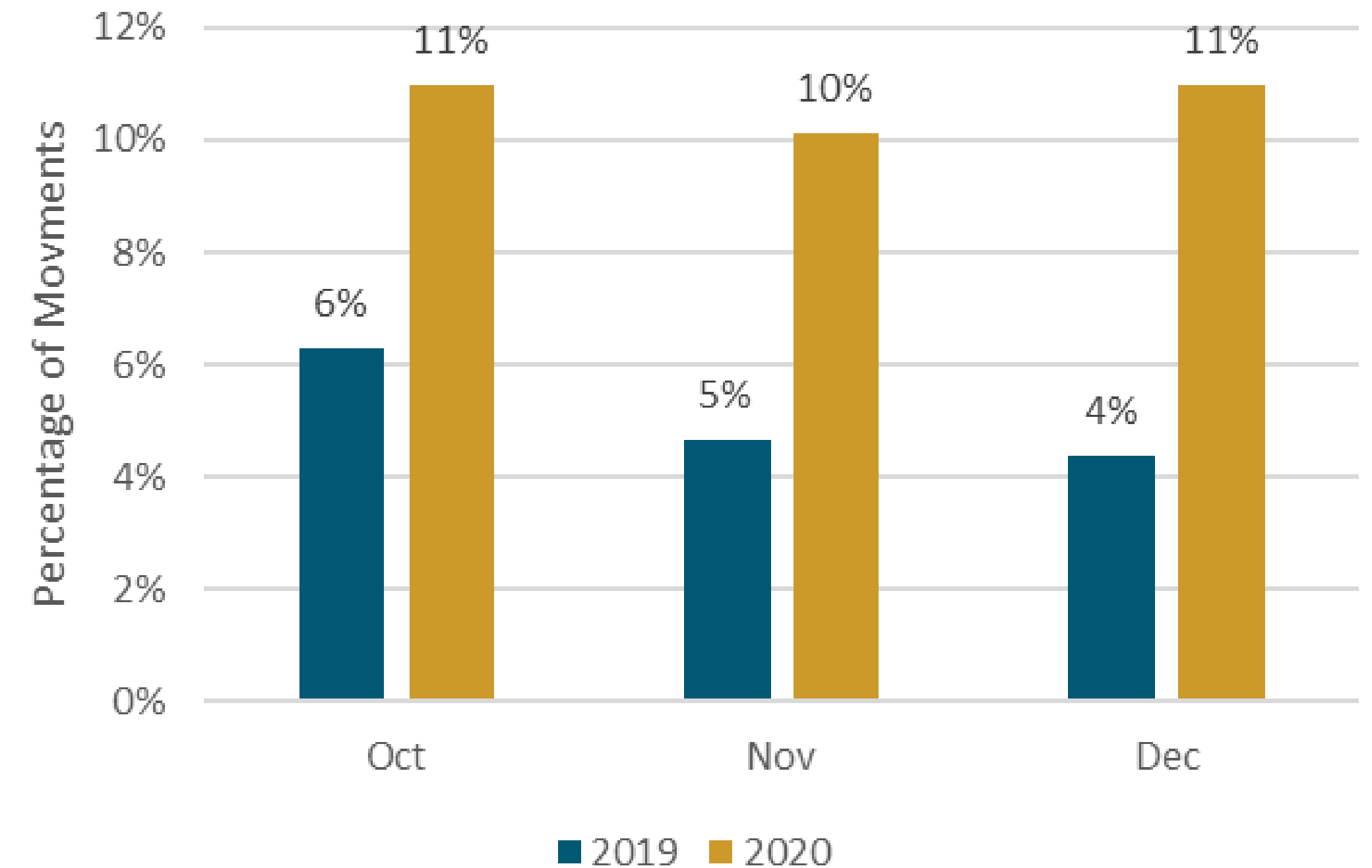

2021-04-09

CALGARY 17L/R JET TURNS

Preliminary Results

Greg Konrad
Manager, Calgary Tower

Serving a world in motion
navcanada.ca



OVERVIEW

Calgary Tower in collaboration with the Calgary Airport Authority is currently trialing new departure procedures that are intended to:

- › Deliver noise mitigation to communities south of the airport
- › Respond to airport infrastructure changes
- › Improve air traffic management during high demand periods (or, as in this past year has been low traffic demand)

17R JET DEPARTURES

Summary Statistics – October to December

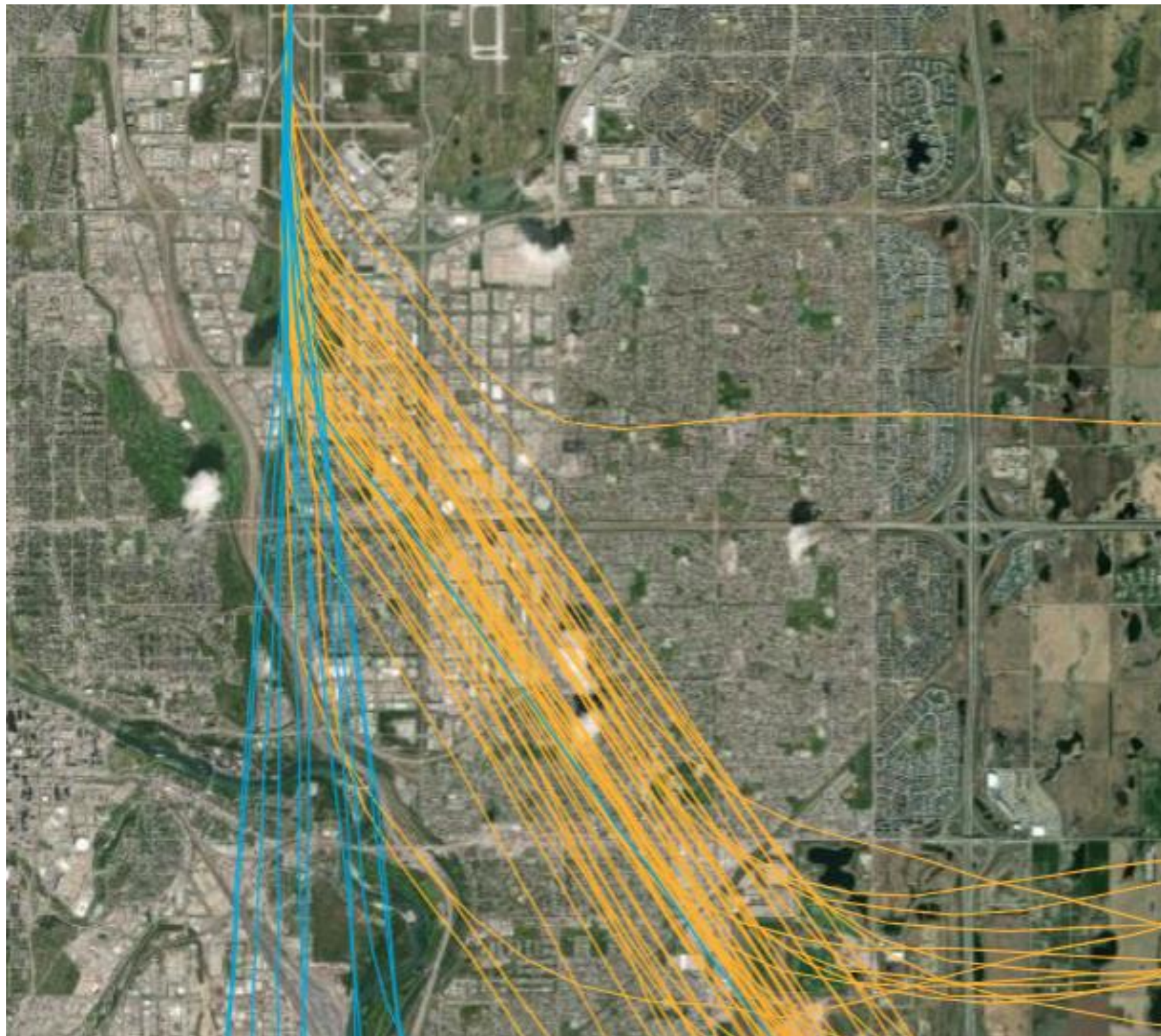

Tracks for turn-eligible flights: December 1st to December 8th, 2020.

- › **1,745 jets** departed off of 17R in total
- › Of these, **51%** or **896 departures**, were eligible to turn to a heading of 135°:
- › **45%** of total departures (**779 departures**) turned to a heading of 135°

17R JET DEPARTURES

Summary Table – October to December

Month	Turned	Not Turned	Not Eligible	Total
Oct.	221	69	262	552
Nov.	331	31	337	699
Dec.	227	17	250	494
Total	779	117	849	1,745

2021-01-12
Source: EXCDS

Prepared By: Corporate Performance

17L JET DEPARTURES

Summary Statistics – October to December

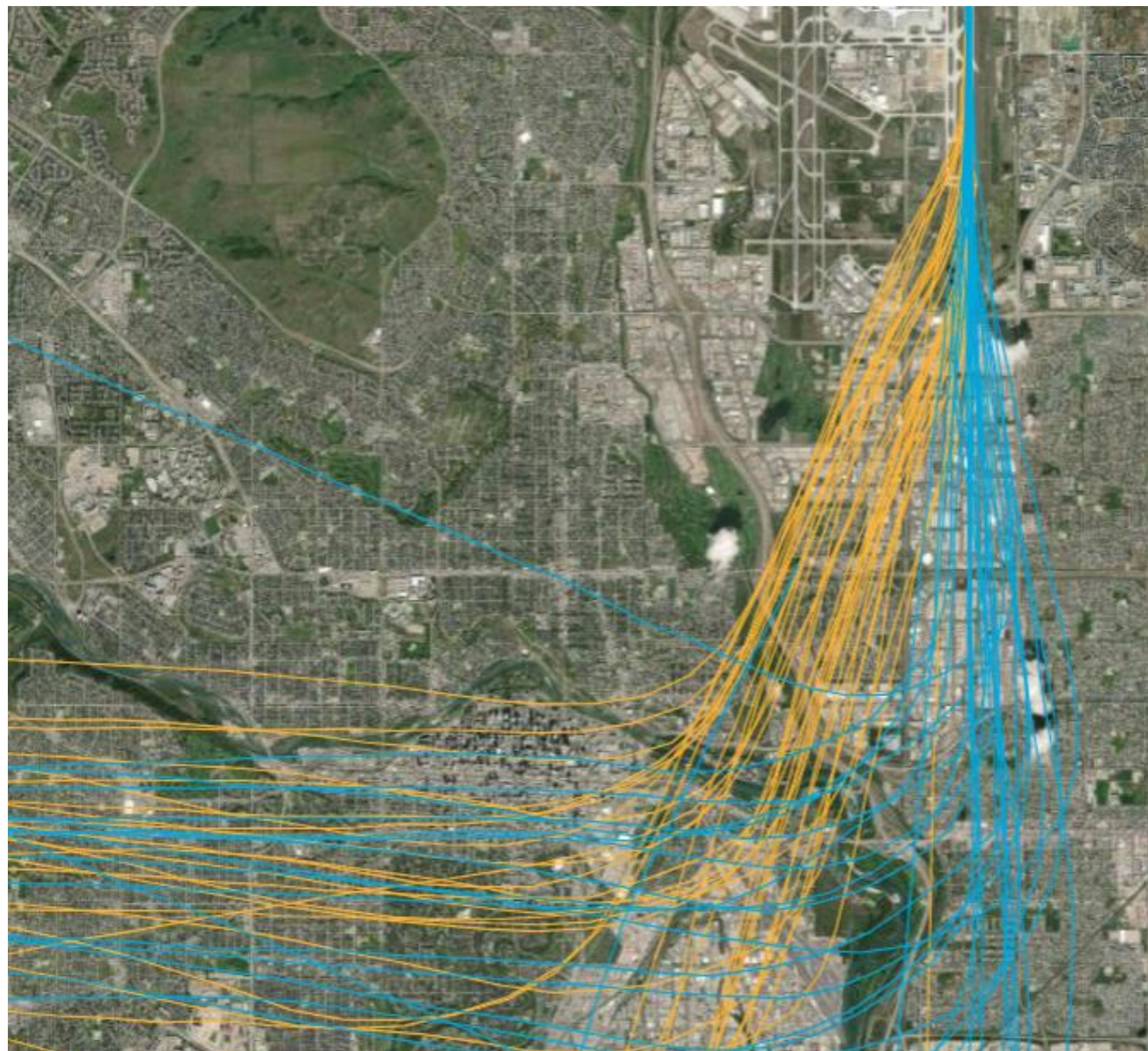

715 jets departed off of 17L in total

Of these, **9%** or **63 departures**,
were eligible to turn to a heading of
135°:

5% of total departures (**34
departures**) turned to a heading of
185°

Tracks for turn-eligible flights: October 1st to December 31st, 2020.

2021-01-12
Source: EXCDS, RDPSR
Prepared By: Corporate Performance

17L JET DEPARTURES

Summary Table – October to December

Month	Turned	Not Turned	Not Eligible	Total
Oct.	8	18	201	227
Nov.	16	7	184	207
Dec.	10	4	267	281
Total	34	29	652	715

2021-01-12
Source: EXCDS

Prepared By: Corporate Performance

BENEFITS

Environmental	Operational
Increased noise distribution for departures, and ability to distribute regardless of runway in use.	Reduced complexity in moving aircraft on the ground and reduced active runway crossings
Departures from 17R more likely to overfly non-residential use land at lowest altitudes	Consistency for the controller in allowing the same techniques to be applied in either flow (north/south).
Departures from 17L more likely at a greater altitude when they reach residentially populated areas	Improved utilization of changes to ground infrastructure
Reduced greenhouse gas emissions as a result of reduced taxiing and more direct routing	Increased ability to move traffic in a timely manner during peak periods

TRIAL – KEY CONSIDERATIONS

- › Trial format provides an opportunity to assess the benefits to the communities – intended 1 year trial (due low traffic it has been extended to the end of 2021)
- › Initial briefing to the airport’s community consultative committee (ACCC) provided on September 18th
- › A public notice was published on the airport’s website and shared with YYC’s email distribution list
- › Committed to updating the ACCC on performance of the trial at scheduled meetings (4x/year)
- › Your feedback is welcomed
- › As the trial has been extended, further public engagement/consultation will be conducted in coordination with the Calgary Airport Authority (expect an information on the plan at the next ACCC)

QUESTIONS ?



Serving a world in motion
navcanada.ca





MEMBER ROUND TABLE